



ENGINEERING |

POWER-PACK |

ASSEMBLIES |

SERVICE

BIPOWER

hydraulic unit by **BIBUS®**

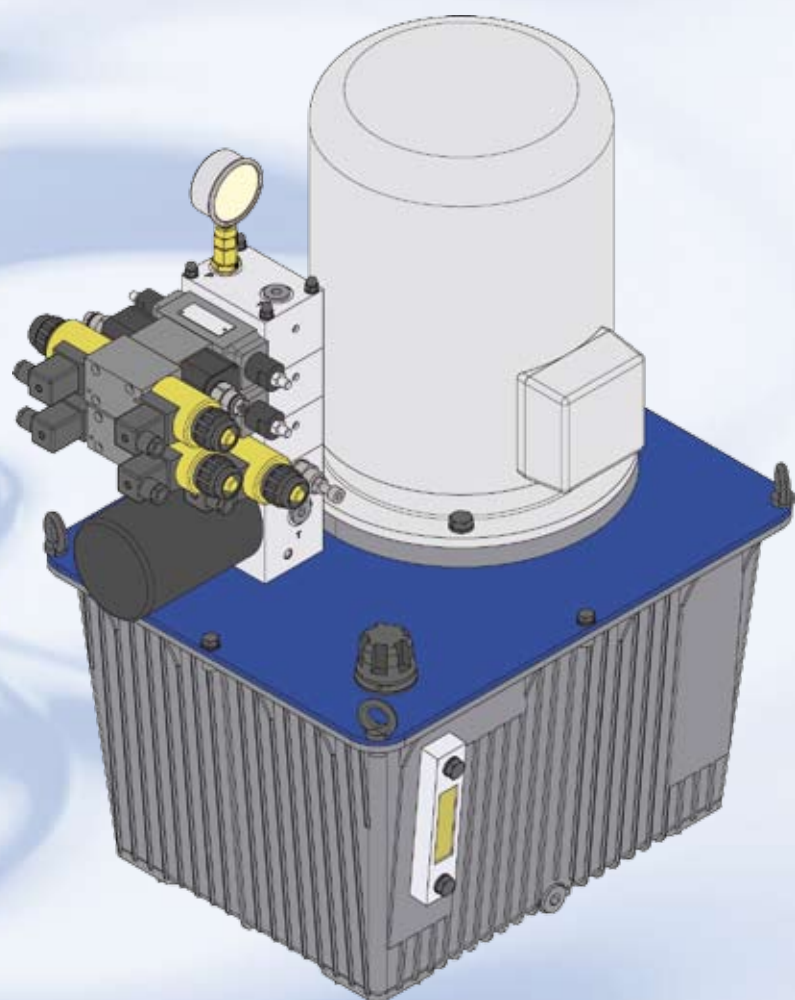
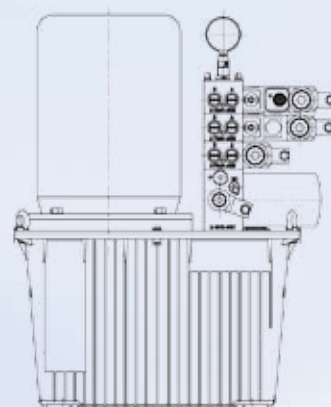
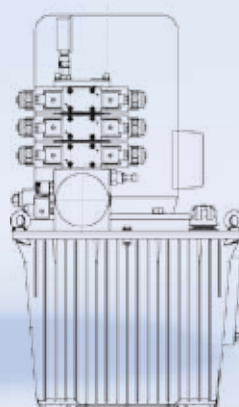

BIPOWER - 110 - 040 - 040 - DC - . 2 . /

Code	Power
055	0.55 kW, 230/400 VAC, 50 Hz
075	0.75 kW, 230/400 VAC, 50 Hz
110	1.1 kW, 230/400 VAC, 50 Hz
150	1.5 kW, 230/400 VAC, 50 Hz
220	2.2 kW, 230/400 VAC, 50 Hz
300	3 kW, 230/400 VAC, 50 Hz
400	4 kW, 230/400 VAC, 50 Hz
550	5.5 kW, 230/400 VAC, 50 Hz
750	7.5 kW, 230/400 VAC, 50 Hz

Code	Flow at 1500 U/min	Feasible electric-motor power
018	1.8 liter/min	0.55 - 0.75 kW
033	3.3 liter/min	0.55 - 1.5 kW
040	3.9 liter/min	0.55 - 2.2 kW
060	5.7 liter/min	0.55 - 2.2 kW
090	9 liter/min	0.55 - 3 kW
120	12 liter/min	0.75 - 4 kW
160	16.5 liter/min	1.1 - 5.5 kW
210	21 liter/min	1.5 - 7.5 kW
250	25.5 liter/min	1.5 - 7.5 kW

Code	Oil tank capacity
010	10 liter
016	16 liter
025	25 liter
040	40 liter
063	63 liter

Code	Basic multi-stack valve-block
N	without free flow valve
DC	with free flow valve 24 VDC, connector acc. to EN 175301-803
AC	with free flow valve 220 VAC, connector acc. to EN 175301-803

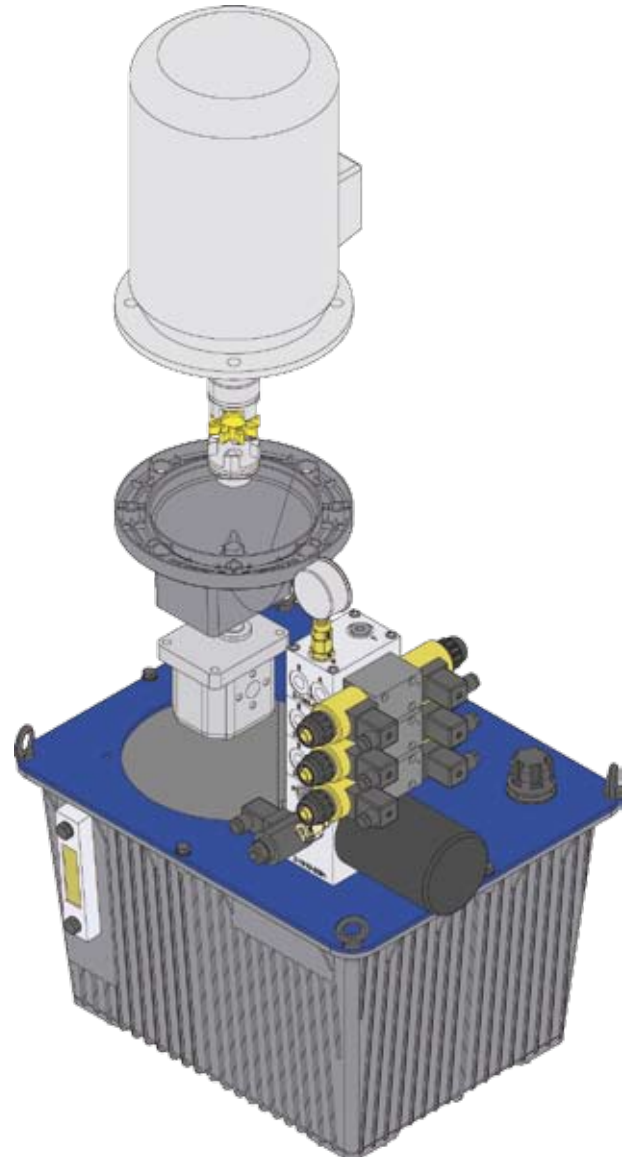

Code	Accessories
NNN	no accessories
1..	level and temperature switch
.2.	smx 10 filter
..3	oil/air cooler
X	specialities



Valve section 1 **Valve section 2** **Valve section 3** **Valve section 4 - 8**
4304 AG - **4304 FG** - **....** **...** - **....** **...** - **DC** - **Q**

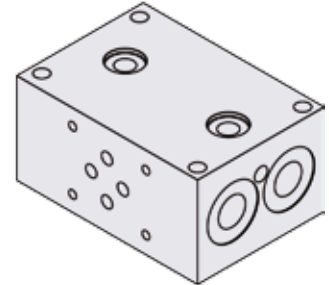
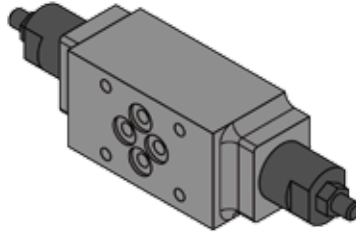
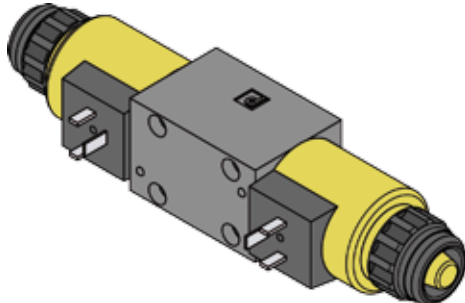

Valves	
Code	Type
4301	
4302	
4303	
4304	
4305	
4206	
4207	
4208	
4209	
3210	
3211	

Multi-stack valve		
Code	Symbol	Type
A		Counter balance valve in A + B 70-210 bar
B		Counter balance valve in A 70-210 bar
C		Counter balance valve in B 70-210 bar
D		Pilot operated check valve in A + B
E		Pilot operated check valve in A
F		Pilot operated check valve in B
G		Throttle check valve A + B drain flow restriction
H		Pressure reducing valve in P 10-160 bar
I		Pressure reducing valve in A 10-160 bar
J		Pressure switch in P 20-250 bar
K		Pressure switch in A 20-250 bar
L		Pressure switch in B 20-250 bar

Coil voltage	
Code	Voltage
DC	24 VDC
AC	220 V / 50 Hz

Accessories	
Code	Type
Q	with connector acc. to EN 175301-803
Z	without connector acc. to EN 175301-803

Multi-stack valve manifold:
The main valve manifold can be extended up to 8 segments.

Valves on intermediate manifolds:
There can be installed up to three multi-stack valves on each manifold segment. Due to specific application there is the possibility to assemble even more than three valves. In these cases please contact our technical support team.

Specialities:
Valves which are not listed in this catalog, but provided in the program of our manufacturer, can be supplied on request. Please contact our technical support team.



Motor sizing (for continuous operation mode)

The motor size depends on the flow (pump size) and the required working pressure.

The following diagram will help you with the sizing of the motor. Depending on the application pressure can be increased after consulting our technical department.

Motor power in kW	Pump flow at 1500 U/min								
	1.8 l/min	3.3 l/min	3.9 l/min	5.7 l/min	9 l/min	12 l/min	16.5 l/min	21 l/min	25 l/min
allowable pressure-adjustment in bar									
0.55 kW	160	87	74	50	32				
0.75 kW	218	119	100	69	44	33			
1.1 kW		174	147	101	64	48	35		
1.5 kW		237	201	137	87	65	47	37	31
2.2 kW			294	201	128	96	70	55	46
3 kW					174	131	95	75	63
4 kW						174	127	99	84
5.5 kW							174	137	115
7.5 kW								186	157

Cooling capacity of the hydraulic oil tank surface

During the operation of the power pack the hydraulic fluid warms up. The produced heat will be dissipated either by radiation through the tank surface and the surfaces of the hydraulic components or by using an optional cooler.

The cooling capacity of the oil tank surface depends on the air circulation. In case of lack air circulation the cooling capacity decreases.

The cooling capacity of the oil tank surface is presented in the following diagram.

If the cooling capacity of the oil tank surface is not sufficient, a cooler has to be installed obligatorily.

Heat dissipation by oil tank surface (approximate value)		
Tank volume	with air circulation	without air circulation
	$\Delta T 30^{\circ}C$	$\Delta T 30^{\circ}C$
10	140 W	100 W
16	170 W	120 W
25	270 W	190 W
40	390 W	270 W
63	510 W	350 W



BIPOWER -055-018-010-DC-.2. / **4304FG-4304AG-DC-Z**

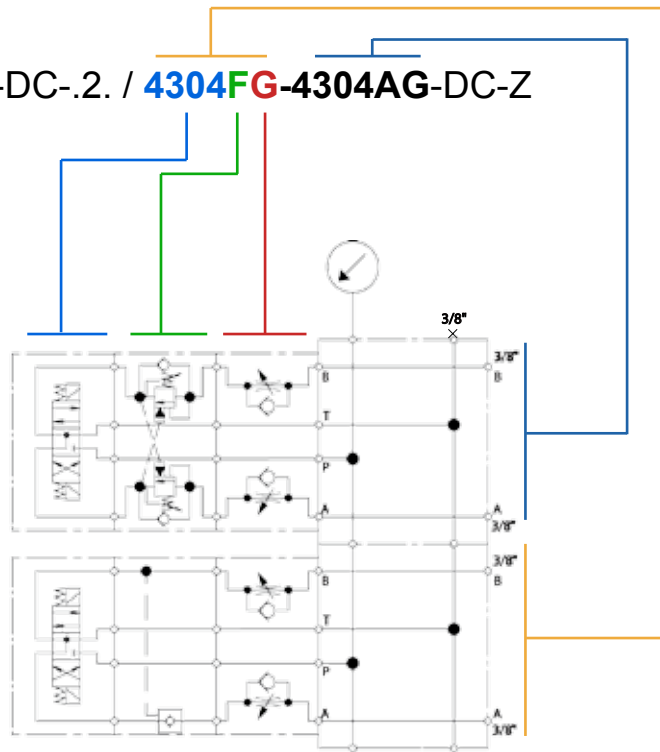

The basic version includes following components:

- Oil tank
- Pump
- Bellhousing
- Electric motor
- Basic stack-valve unit including
 - Filter with by-pass
 - Pressure relief valve
 - Valve for pressureless flow (must be defined in the order code)
- Pressure gauge
- Filling and venting filter
- Level and temperature indicator (must be defined in the order code)

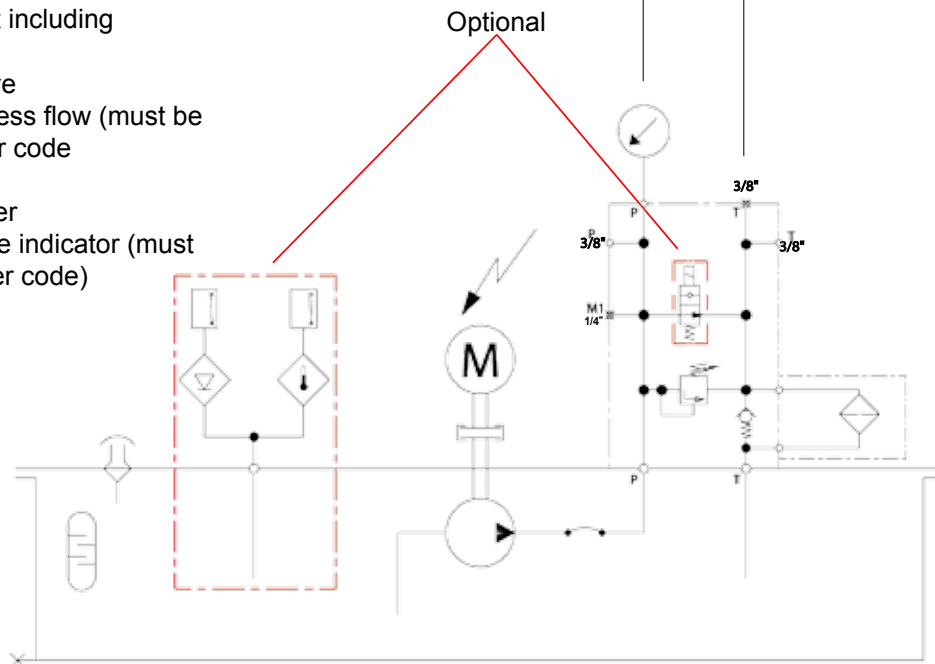

Dimensions (all dimensions in mm)

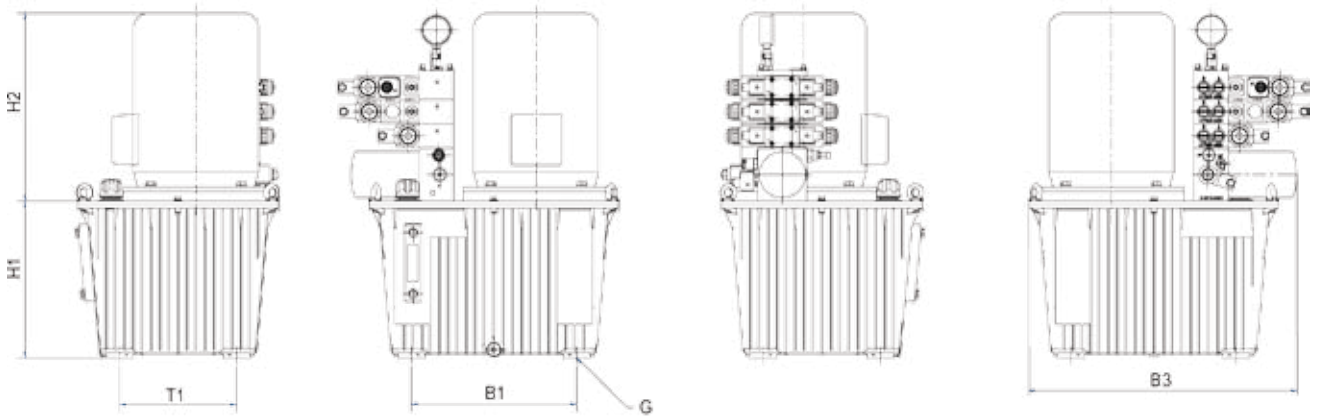

Electric-motor	055	075	110	150	220	300	400	550	750
Power in kW	0.55	0.75	1.1	1.5	2.2	3	4	5.5	7.5
Dimension H2	252	252	268	292	324	324	346	388	426

H2 can vary lowly depending on the motor supplier.

Oil tank	010	016	025	040	063
H1	223	248	291	323	375
T1	170	192	176	241	282.5
T2	247	290	340	415	465
T3	270	348	373	---	---
B1	250	270	326	341	422.5
B2	340	368	490	515	605
B3	454.5	487.5	514.5	552	---
G	M8x16	M8x16	M10x20	M10x15	M10x15

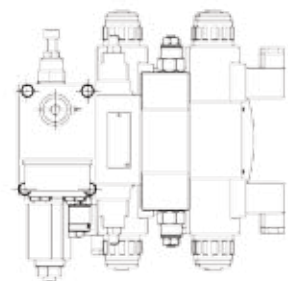
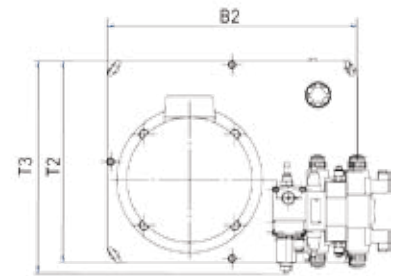

Filter	< 21 l/min	≥ 21 l/min
F	141	210

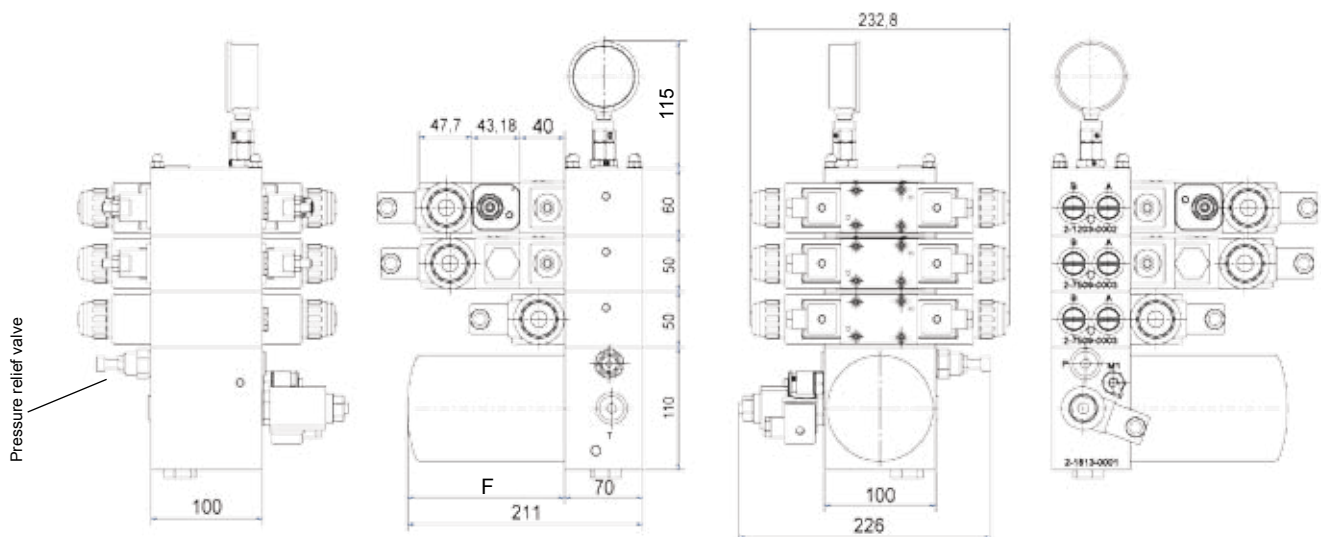

Pressure relief valve



General information

The BIPOWER hydraulic units have a modular design and can be customized regarding sizing, power, and pressure etc. depending on the project requirements. Complex hydraulic systems can be realised due to the modular design and the high variety of available valves. The BIBUS technical support team with its long experience in the development of hydraulic systems stands to your disposal at any time.

Oil tank

The aluminium oil tank with its high thermal conductivity facilitates the good heat dissipation (high cooling capacity).

Electric motor

The 4-pole three-phase asynchronous motors with squirrel-cage rotor can be delivered with power from 0.55 – to 7.5 kW and voltage 230 and 400 Volt, 50/60 Hz. On request motors with higher power and different voltage can also be provided.

Gear pump

The Sauer-Danfoss gear pumps used in the BIPOWER have working pressure up to 250 bar and their superior efficiency is above the average.

Pressure relief valve

A pressure relief valve is integrated in the basic stack-valve unit of BIPOWER. This permits easy adjustment from outside. The factory adjustment of this valve (unless otherwise specified in the model code) will be at maximum working pressure (according to the diagram on page 4). The pressure can be adjusted to the required value during startup procedure on site.

Pressure gauge

All basic BIPOWER units have standard pressure gauges with glycerin filling with range from 0 to 250 bar. The working pressure in the pressure line can be controlled by this gauge.

Filter

In the basic stack-valve unit of BIPOWER a reverse filter and a by-pass valve (2bar) are also integrated. A low-pressure filter with 10 µm paper element is used as standard. As an option a 10 µm glass-fibre filter element ($\beta_{10} \geq 200$) is also available.

Painting

The oil tank is unpainted. The stack-valve manifold and its elements are anodized. The tank cover is painted blue (RAL5015). Stack-valves are in the manufacturer's original color.

Level and temperature switch

On demand, the oil level and temperature can be controlled using a combined level and temperature switch. If oil level drops under the minimum level, the first contact opens. When oil temperature exceeds 70°C the second contact opens (the closing temperature of the switching is at 45°C).

Contact load

Level: 230 VAC/DC; 0.8A / 0.8A ind.;
20W / 26 W

Thermostat: 250 VAC/DC; 2.5A / 1.6 A ind.;
min 50 mA

Connector according to EN175301-803

Clamp assignment:

2 = level
3 = temperature
1 = common
PE = mass

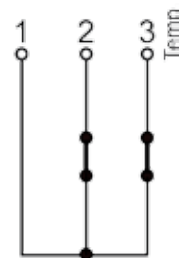

Connection to electric network

The units are usually delivered without electrical control and wiring.

The electric control as well as the wiring of the electric components (motor, magnets, breakers and lamps) is usually provided by the customer. In this case the relevant VDE-regulations as well as the voltages and frequencies according to the specifications and indications in list's and labels of the devices must be observed.

On request the BIPOWER unit can be provided by BIBUS including electric control and complete wiring.

Explosion protection

The BIPOWER units can be delivered, on request, in ATEX-version. Please contact our technical support team.



Operation and maintenance instructions

The assembly, start-up procedure and maintenance of the BIPOWER unit must be performed only by professionals. BIBUS Hydraulik does not take responsibility for damages caused by improper handling.

General information

In order to preserve the good functioning of the BIPOWER-units during operation following instructions must be observed:

Cleanliness must be provided during maintenance and repair works. Generally it is prohibited to open or tighten bolt/screw connection while the equipment is under pressure.

Leakages

In case leakages should occur the load must be decreased and the electric motor must be stopped.

In case there is an accumulator in the system it has to be emptied; otherwise the risk of an accident increases. Before unscrewing bolt connections, disassembling of pipes etc. the vicinity area must be well cleaned. All openings shall be closed with plugs or rubber caps in order to avoid loss of hydraulic fluid and to prevent penetration of contamination in the equipment. Damaged pipes or hoses must be replaced. For this purpose only seamless precise pipes are permitted. Only hoses released for the maximum working pressure must be used.

Hydraulic fluids, general information

Only hydraulic fluids whose compatibility with the used sealing elements (O-rings, radial sealing rings, U-shaped sealing rings, collars etc.) has been guaranteed can be used in the hydraulic equipment. The mixing of hydraulic fluids is not permitted. Please consider the instructions of the manufacturer of the used hydraulic fluid. When choosing the type of hydraulic fluid its viscosity is of great importance. Temperatures under most unfavorable conditions must be taken into account.

Check of the hydraulic fluid level

The level-check of the hydraulic fluid shall be performed at least once a week, depending on the operating conditions – even daily, when the equipment is warm and working, the driving motor is switched off and, if possible, with cylinders in end upper posi-

tion. Leakages must immediately be repaired and in case of loss of hydraulic fluid its quantity has to be restored.

Temperature of hydraulic fluid

If the hydraulic fluid has very low temperature at the beginning of work and after long breaks, it is recommended that the unit should be left for 5-10 minutes to warm up. If possible, the equipment should not be loaded (pressureless flow). The temperature of hydraulic fluid, however, shall not exceed 70°C. In case the cooling capacity through dissipation of the tank surface is not sufficient, the installation of oil/air cooler is obligatory.

Replacement of hydraulic fluid

The first replacement of hydraulic fluid must be done after 500 working-hours. After this first replacement the hydraulic fluid can be replaced in a cycle of 2000 working-hours.

Filter-element replacement

The first replacement of the return filter-element must be done 250 working-hours after the start-up procedure. All other filter-element replacement can be performed when replacing the hydraulic fluid (after 2000 hours of operation), at least once a year.

Spare-part filters elements:

HC6 MIC10	7501273
HC2 MIC10	2013241
HC46 SMX 10	7501232
HC42 SMX 10	7501372

Warranty

The warranty terms and conditions are in compliance with our general terms and conditions of sale and delivery. The updated version can be found on the Internet under the following address: www.bibus.ch.



Recommendations for hydraulic fluid

The mineral oil is offered in different viscosity grades (VG, viscosity grade). The given numerical value shows the nominal viscosity in mm²/s at 40°C:

VG 22 arctic conditions,
extremely long lines

VG 46 normal environment,
closed rooms

VG 32 winter conditions

VG 68 tropical environment

Viscosity - Temperature Diagram for mineral oils

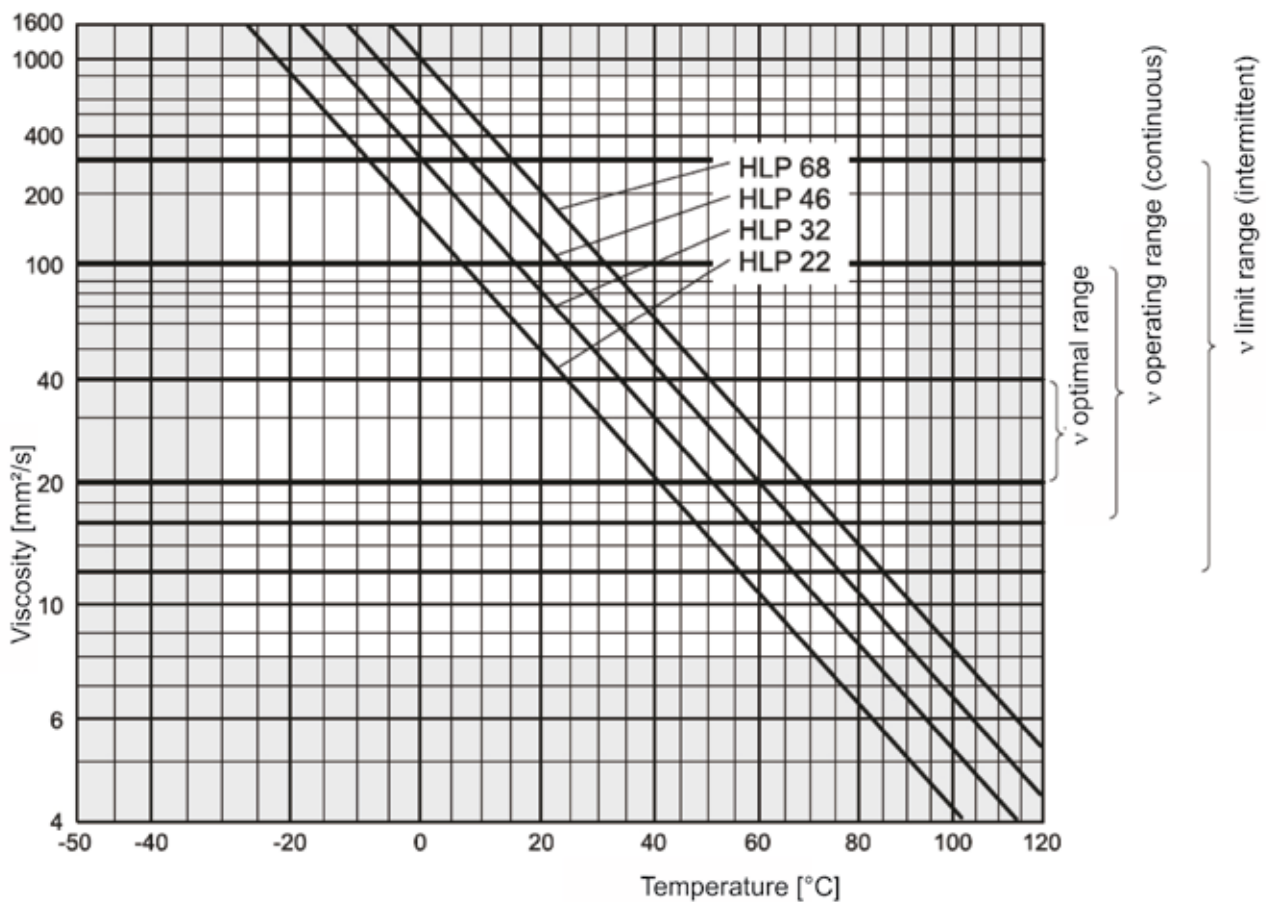

Ubbelohde Diagram – dependency of viscosity and temperature presented in double logarithmical diagram.

Preserved right of technical changes

The content of the present catalogue of BIPOWER-power-packs has been compiled very carefully according to our current level of knowledge.

with the further technical development of our products.

If you have any further questions, please do not hesitate to contact our technical support team.

Nevertheless, we would like to underline that the updating of the leaflet cannot always coincide in time

